

Ventilateur type CMV 125-400 Entraînement par courroies

Modifications réservées

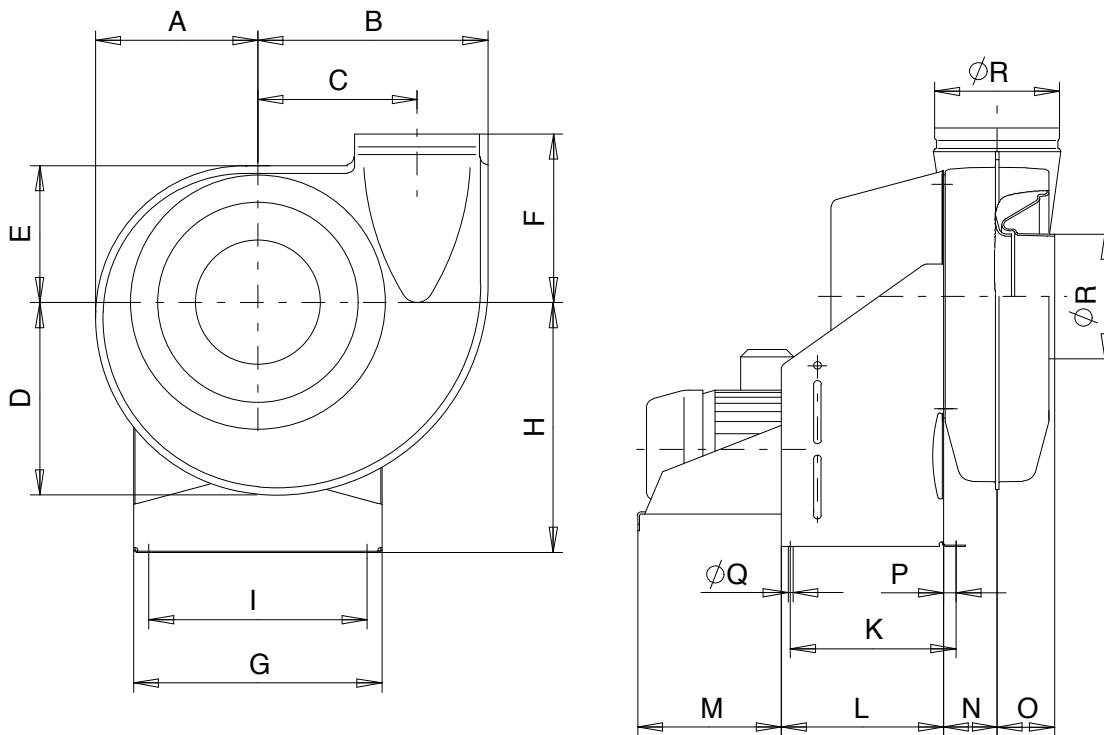

CMV	125	160	180	200	225	250	280	315	400
A	172	213	236	260	289	318	350	395	445
B	240	300	335	369	412	455	502	567	656
C	164	206	231	255	286	316	348	396	441
D	203	252	280	309	345	380	419	473	540
E	153	180	199	219	243	267	293	330	368
F	200	225	250	275	300	330	365	400	425
G	274	324	358	398	448	495	548	613	688
H	280	335	375	400	450	500	560	630	710
I	230	280	310	350	390	435	480	545	620
K	210	215	225	265	285	285	295	335	370
L	205	210	220	260	275	275	285	325	360
M	199	199	211	216	270	360	260	219	274
N	56	70	76	86	96	106	118	131	165
O	80	75	65	80	85	95	107	120	100
P	20	20	20	20	30	30	30	30	30
ϕQ	8	10	10	10	12	12	12	12	12
ϕR	125	160	180	200	225	250	280	315	400

